

GELATO *Gelato*



VETRINA GELATO
Gelato cabinet



REFRIGERAZIONE VENTILATA
Ventilated refrigeration



REFRIGERAZIONE VENTILATA CON DOPPIO FLUSSO DELL'ARIA
Ventilated refrigeration with double air flow



DREAM

GELATO 1V

Pannellata / Panelled

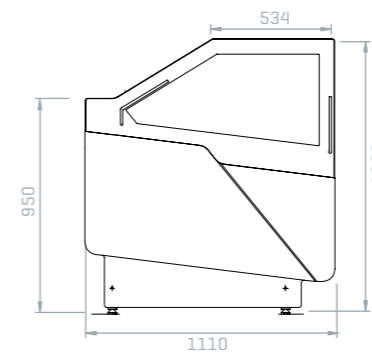
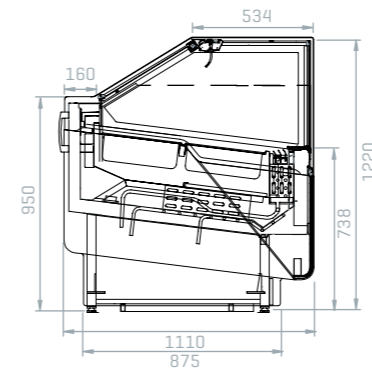

GELATO 2V

Pannellata / Panelled

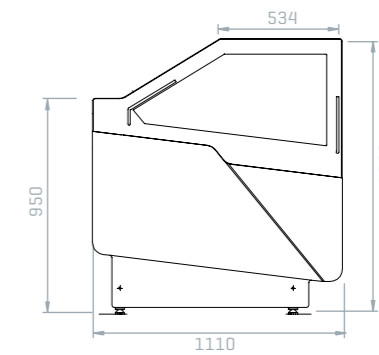
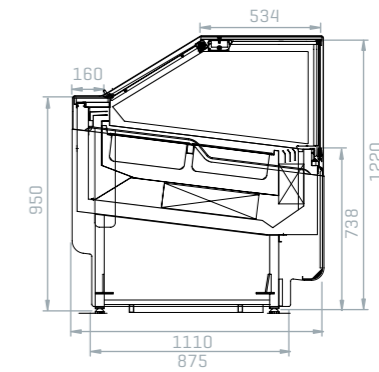

CARATTERISTICHE TECNICHE

technical specifications

Refrigerazione ventilata con doppio flusso d'aria. Sbrinatorio degli evaporatori veloce (90") ad inversione di ciclo. Castello vetri termico alimentato elettricamente, vetro frontale apribile dall'alto verso il basso. Unità condensatrice ermetica 230V/50 Hz oppure semi-ermetica 380V/50Hz.

Ventilated refrigeration with double air-flow system
High speed (90") automatic reverse cycle evaporators defrost
Heated glass superstructure, bottom-hinged opening front glass
Hermetic condensing unit 230V / 50Hz or semi-hermetic 380V / 50Hz.

Vaschette Containers

5 Lt.

7 Lt.

8 Lt.

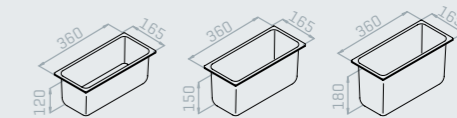

7 Lt.

10 Lt.

12 Lt.

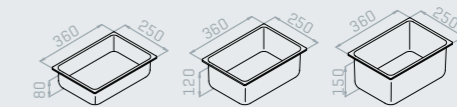

14 Lt.

