



- TASTE THE DIFFERENCE -

## MODEL 30T-RMT

This high volume, front-loading freezer with refrigerated cabinet was designed for high-traffic specialty ice cream and custard stores. The 2 flavor twist machine is great for all mixes, but especially high butter-fat mixes like custard and premium ice creams. Our pressurized machines consistently produce smooth and creamy product. Perfect for full-menu ice cream stores and custard shops.

### The Electro Freeze Advantage

- **Patented Mix Transfer System\*** simplest and most reliable pressurized system available
- **Flexible Mix Holding System** pumps directly from bags or from mix containers
- **The Finest Frozen Product**, consistently the best frozen product available. Smooth, creamy and profitable
- **Self Closing Spigots** prevents the mess and eliminates waste
- **Adjustable Dispense Rate** set to meet your specific dispensing speed and volume requirements
- **Exclusive Auger Design** gently blends, reducing agitation, maintaining product quality and consistency.
- **Energy Conservation Mode** reduces energy cost and holds product safely during non-business hours
- **Superior Low Temperature Refrigeration System** provides the best in class production and product quality
- **Product Flexibility** serves a variety of frozen products, custard, ice cream sorbets, water ice or yogurt
- **Experience Tells** Electro Freeze has been manufacturing quality frozen treat machines since 1929. Superior engineering, product innovations, sturdy construction, quality craftsmanship and dependable performance are Electro Freeze hallmarks.
- **Superior Service Support** backed by a world-wide distributor network

\*U.S. Patent #5,349,825

## PRESSURIZED SOFT SERVE FREEZER

Freedom 360° Series



[electrofreeze.com](http://electrofreeze.com)

FOR MORE INFORMATION CONTACT

800-755-4545 • [sales@electrofreeze.com](mailto:sales@electrofreeze.com)

30T-RMT Soft Serve Freezer

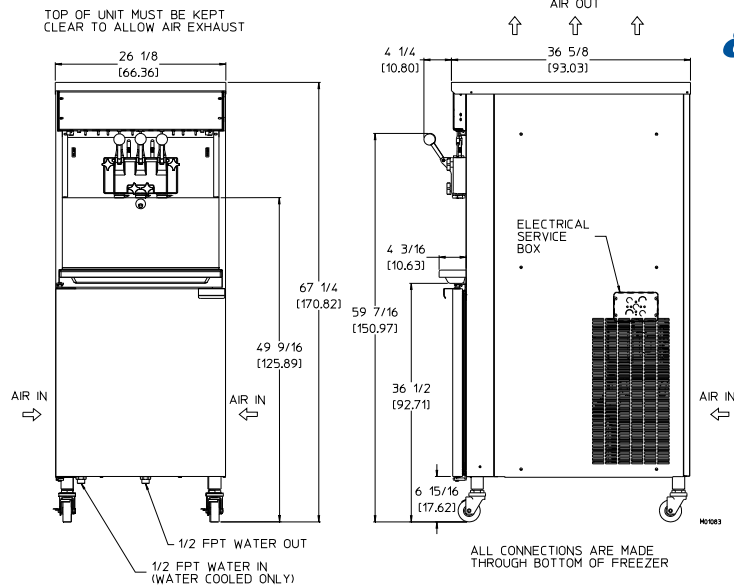

**MODEL 30T-RMT SPECIFICATIONS**

Due to continual product improvements all specifications are subject to change without notice.

<b>Weights</b>	<b>lbs.</b>	<b>kgs.</b>	
Net	847	384	
Crated	965	437	
	<b>cu.ft.</b>	<b>cu.m.</b>	
Volume	58.42	1.65	
<b>Dimensions</b>	<b>in.</b>	<b>cm.</b>	
Width	26-1/8	66.36	
Depth	36-5/8	93.03	
Height	67-1/4	170.82	
<b>Electrical</b>	<b>Maximum Fuse Size (Qty)</b>	<b>Minimum Circuit Ampacity (Qty)</b>	<b>Poles (P) Wires (W)</b>
208-230/60/1 Air	35 (2)	27 (2)	2P, 2W
208-230/60/1 Water	30 (2)	24.5 (2)	2P, 2W
208-230/60/3 Air	25 (2)	19 (2)	3P, 3W
208-230/60/3 Water	20 (2)	16.5 (2)	3P, 3W
	<b>Total Amps (Qty)</b>		<b>Poles (P) Wires (W)</b>
400/50/3 Air	10.7 (2)		3P, 4W
400/50/3 Water	8.5 (2)		3P, 4W

Electrical characteristics other than above available on request from factory or local distributor. Check nameplate for exact electrical data.

**Bidding Spec**

Electrical: Volt \_\_\_\_\_ Hz \_\_\_\_\_ Ph \_\_\_\_\_  
 Cooling: \_\_\_\_\_ Neutral \_\_\_\_\_ Yes \_\_\_\_\_ No \_\_\_\_\_  
 Options: \_\_\_\_\_

**Electrical**

Two dedicated electrical connection are required. Manufactured to be permanently connected. See electrical chart for the proper requirement. Consult your local electrical codes for cord and receptacle specifications.

**Beater Motor**  
Two, 2 hp.

**Refrigeration Systems**  
Two, 9300 Btuh. R404a.

**Air and Water Cooled**  
6" (15.2 cm) air space required at rear panel or both side panels and 18" (45.7cm) air space above unit for proper air circulation.

**Mix Tank Capacity:** two - 26 quarts (24.6 liters) each  
**Freezing Cylinder Capacity:** two - 5 quarts (4.7 liters) each

Certified and/or listed by:



\*UL listed and listed by Underwriters Laboratories under Canadian National Standard C22.2 No. 120-M91 (R2008)  
 \*\*Select Voltages @ 50HZ



**Electro Freeze div. of H.C. Duke & Son, LLC**  
 2116-8th Avenue, East Moline, Illinois 61244 USA  
 Phone (309) 755-4553 • (800) 755-4545  
 FAX (309) 755-9858  
 E-mail: sales@electrofreeze.com • www. electrofreeze.com

**Authorized Distributor**